



Politechnika Poznańska  
Kampus „WARTA”  
Ul. Prof. Jacka Rychlewskiego

[www.ergolab.put.poznan.pl](http://www.ergolab.put.poznan.pl)

# Laboratorium Ergonomii i Bezpieczeństwa Pracy

Laboratory of Ergonomics and Occupational Safety

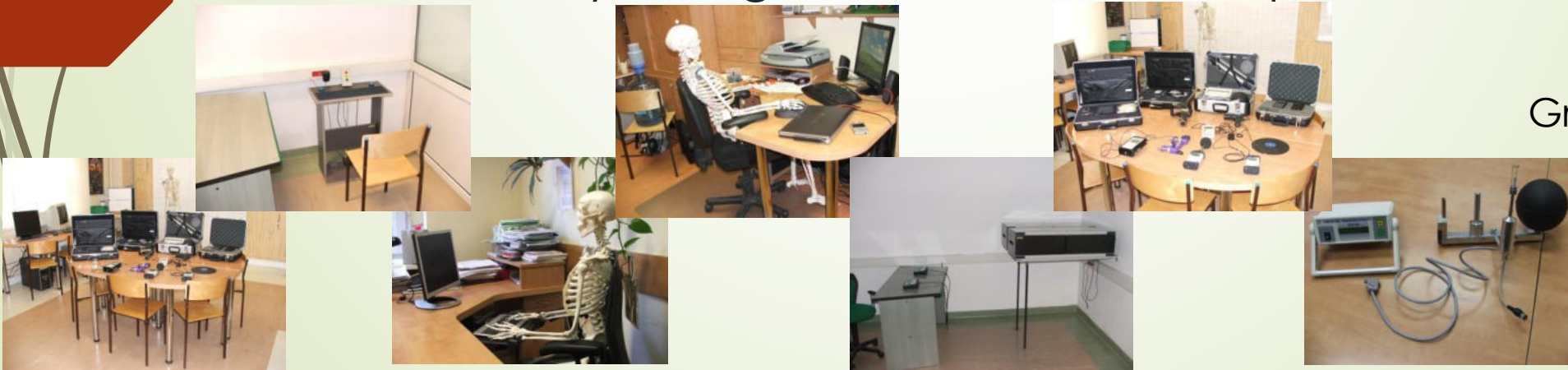

Grzegorz Dahlke

# Plan prezentacji

- Potencjał dydaktyczny:
  - Aparatura i aplikacje komputerowe
  - Zajęcia laboratoryjne;
  - Staże;
  - Prace dyplomowe;
  - Budowa nowych stanowisk laboratoryjnych i aparatury pomiarowej;
- Potencjał badawczy:
  - Aparatura badawcza
  - Eksperymenty badawcze;
  - Walidacja metod pomiarowych dla celów ergonomii;
- Współpraca dydaktyczno-badawcza
- Działania promocyjne:
  - Katalog aparatury;
  - PFNiSz, NN, DD, FB;
  - WTK;

# Potencjał dydaktyczny

## Pomiary psychometryczne

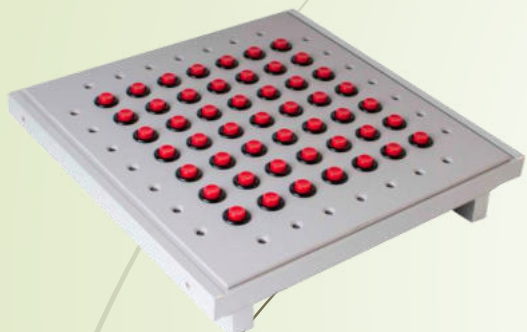

# Potencjał dydaktyczny

## Pomiary fizjologiczne



# Potencjał dydaktyczny

## Pomiary środowiska pracy



# Potencjał dydaktyczny

## Pomiary biomechaniczne

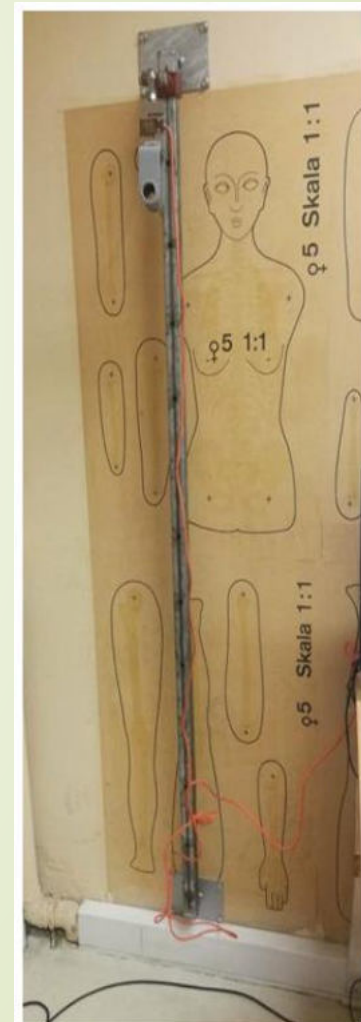
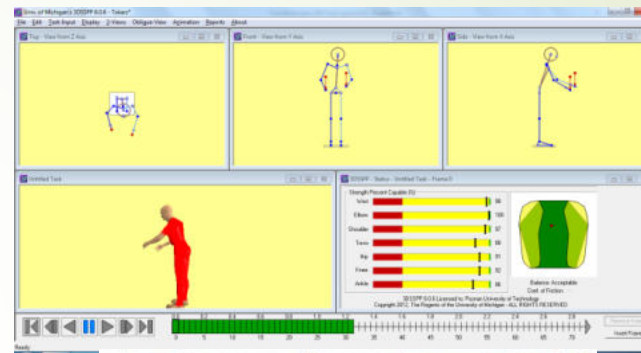

# Potencjał dydaktyczny

## Koło Naukowe Ergonomii

- Kursy w zakresie obsługi aparatury pomiarowej wykorzystywanej w diagnozowaniu SWP i środowiska pracy;
- Kurs modelowania symulacyjnego warunków ewakuacji z wykorzystaniem aplikacji Pathfinder, zakończony Certyfikacją kompetencji;
- Udział w Dniach Organizacji Studenckich i Kół Naukowych;
- Projekt modelu trójwymiarowego nowego budynku Wydziału Inżynierii Zarządzania w programie Pathfinder oraz analiza warunków ewakuacji dla wybranych scenariuszy organizacyjnych;

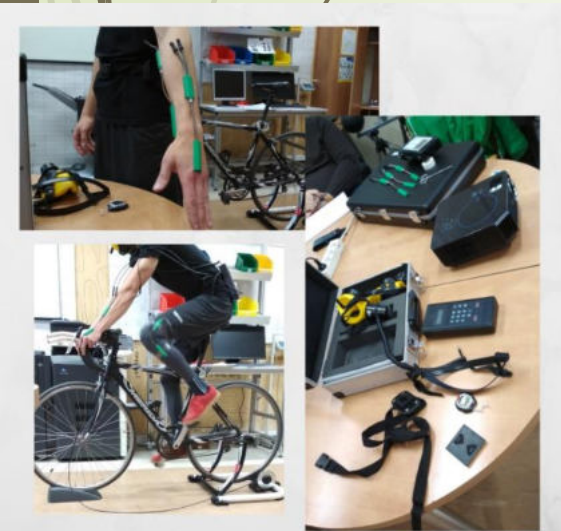

# Potencjał dydaktyczny

## Aparatura i aplikacje komputerowe

- ErgoEaser
- STIAD
- SOWD
- SDP
- Pomiar czynnika
- Axis FM
- GMON
- Svan PC
- Svan Supervisor
- Biometrics DataLog
- Apolinex



- Pyrosim
- Pathfinder
- ErgoIntelligence™ Manual Materials Handling (MMH)
- ErgoIntelligence™ Upper Extremity Assessment (UEA)
- 3D Static Strength Prediction Program
- DELMIA i Catia v.6
- Tecnomatix Mfg Acad (Grant w ramach Programu GO PLM firmy Siemens)
- Aloha



# Modelowanie

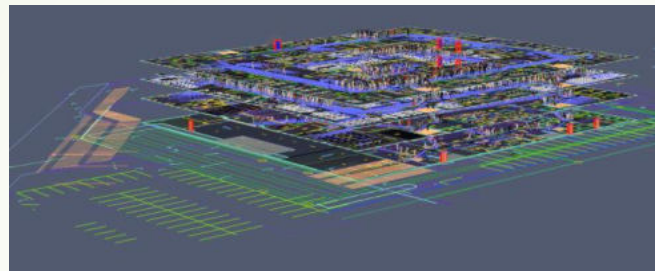
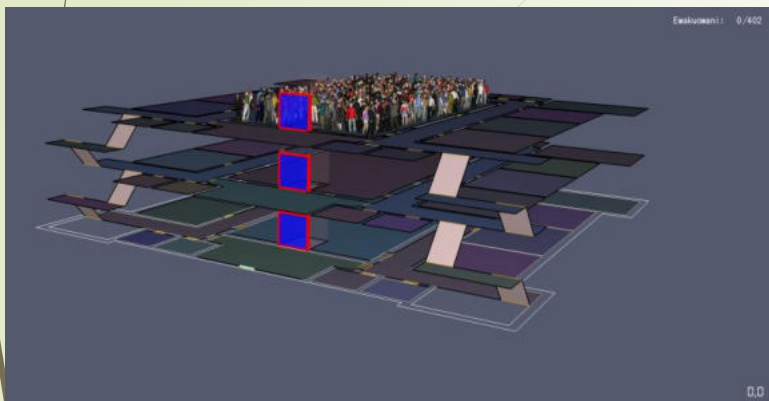

warunków ewakuacji;

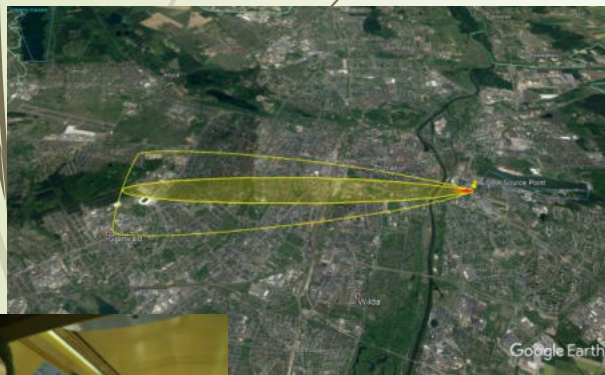

skutków pożarów i wybuchów-  
mapy zagrożeń

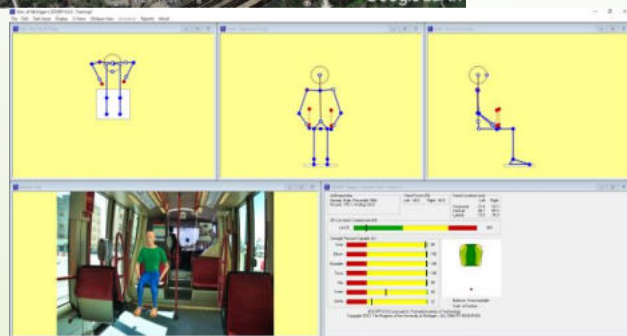

założeń projektowych

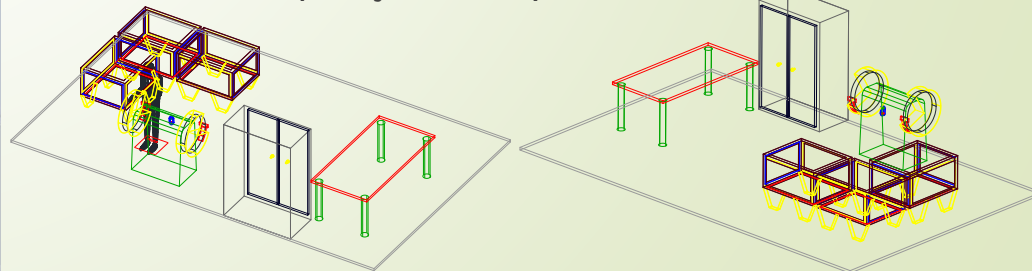

# Potencjał dydaktyczny

## Zajęcia laboratoryjne

- Ergonomia na kierunkach: IB, IZ i L
- Diagnozowanie Środowiska Pracy
- Diagnozowanie Sposobu Wykonywania Pracy
- Modelowanie Zagrożeń
- i inne...
- Studia podyplomowe:
  - BHP;
  - TECHNIKA Z WYCHOWANIEM KOMUNIKACYJNYM.

# Potencjał dydaktyczny

## Zajęcia laboratoryjne cd.

www.ergolab.put.poznan.pl

**Laboratorium Ergonomii i Ryzyka Zawodowego**  
Politechniki Poznańskiej  
<http://www.ergolab.put.poznan.pl>

STRONA GŁÓWNA WYDZIAŁ INŻYNIERII ZARZĄDZANIA

**Menu główne**

- Ergonomia
- Struktura
- Dydaktyka
- Badania
- Prace dyplomowe
- Współpraca
- Artykuły
- Pobierz
- Dyżury

**Kontakt**

**NOWE**

- SWP

**Linki**

- Politechnika Poznańska
- Wydział Inżynierii Zarządzania
- SIFE
- KN Progress
- PTERG
- OSHA
- MNISW
- Koło Naukowe Ergonomii

**Konferencje**

- ISET
- II KONGRES ERGONOMII

**Wojciech Bogumił Jastrzębowski (1799 - 1882)**

::: webmaster: Krzysztof Kopera :::



# Potencjał dydaktyczny

Staż - The International Association for the Exchange of Students for Technical Experience (IAESTE)- od 2015 roku

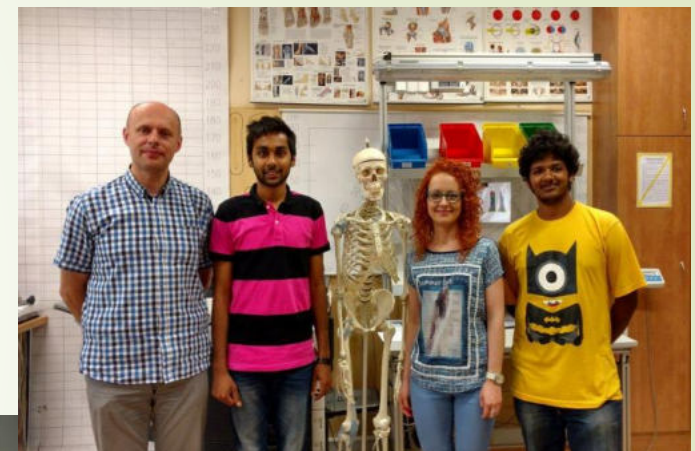

# Potencjał dydaktyczny

Budowa nowych stanowisk laboratoryjnych i aparatury pomiarowej

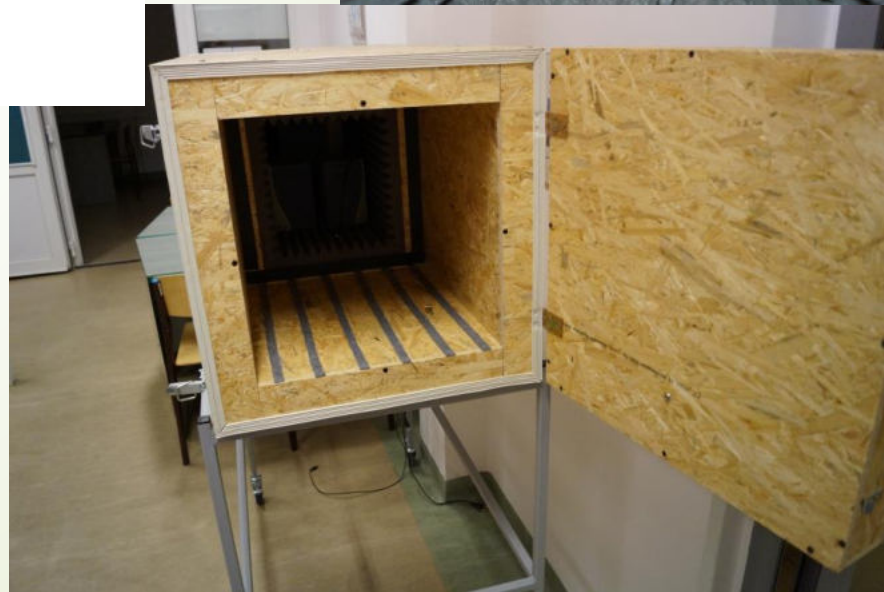
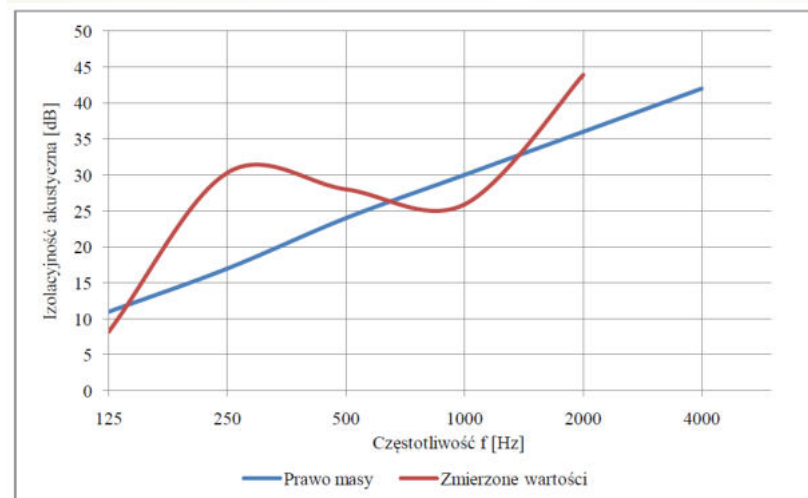
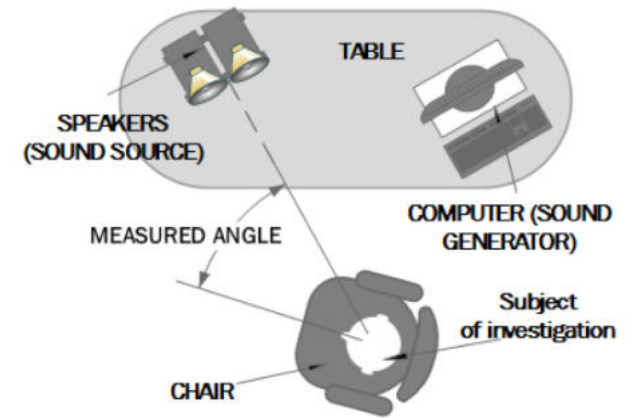
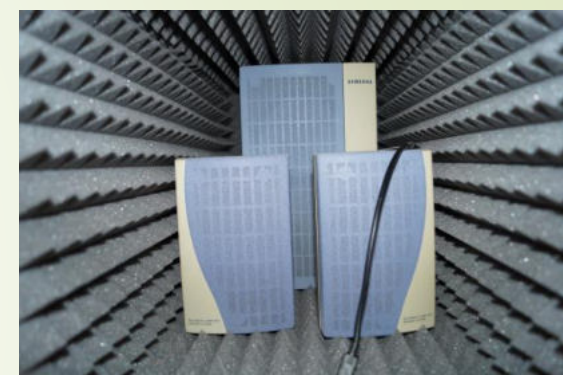
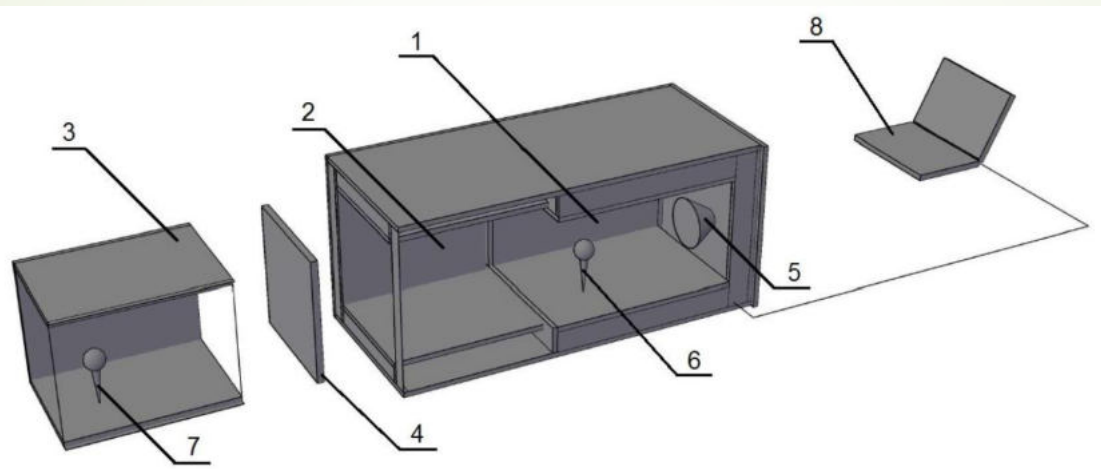
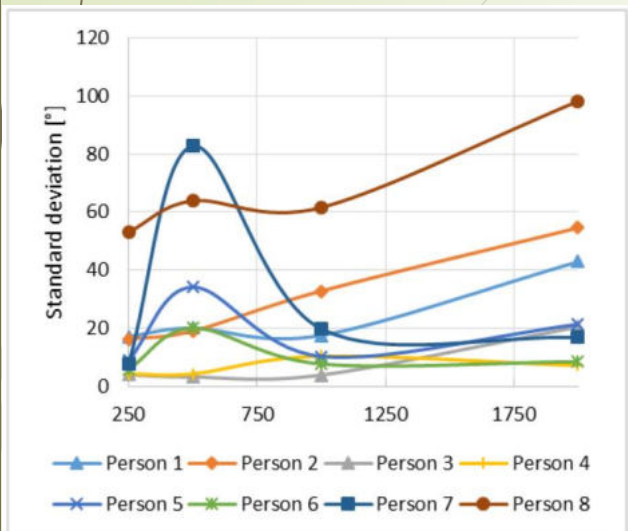
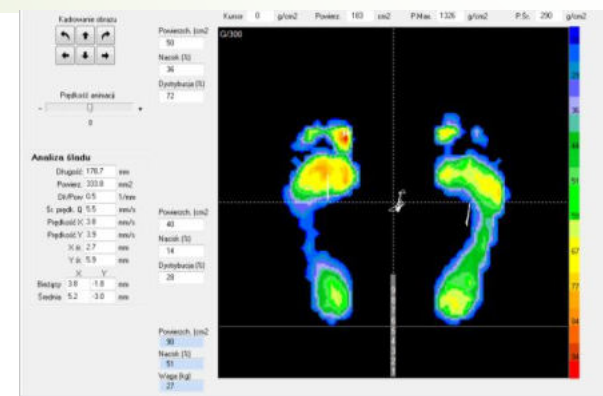

Figure 1. Sound source location identification station designed for conformity with accepted methodology (Ptak 2017).

# Potencjał badawczy

## Aparatura badawcza



WYDZIAŁ INŻYNIERII ZARZĄDZANIA

# Współpraca dydaktyczno-badawcza

- Ekspertyzy
- Laboratoria innych uczelni
- Projektowanie wyrobów



# Potencjał badawczy

## Eksperymenty badawcze

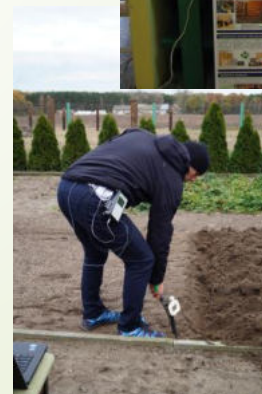
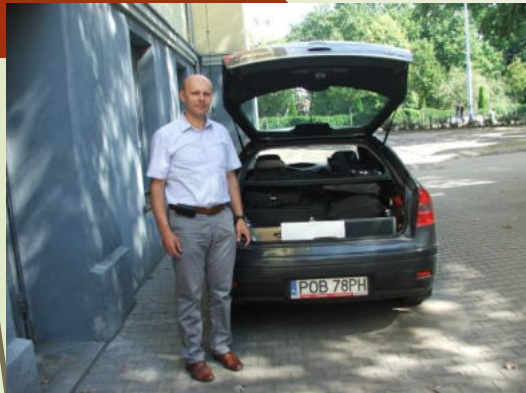

# Działania promocyjne

- Poznański Festiwal Nauki i Sztuki
- Noc Naukowców
- Dzień dla Dziewczyn na Politechnice Poznańskiej
- Forum Biznesu



